

# 6.1

## Ex-Distributions in Moulded Plastic Design

Modular design GHG 619

### Safety for your protection

CEAG products provides explosion protection in a snap – and that also applies to distributions.

Electrical distributions for Ex-areas must be protected according to EN 60079 by constructional measures. Thus, the Eaton's Crouse-Hinds Business flameproof moulded-plastic distributions provide type Ex-e protection.

The enclosure and main-switch modules are available in the following materials: fibreglass reinforced polyester, electro-polished stainless steel and polyester powder-coated steel. Moulded plastic enclosures are flame-retardant according to UL 94 VO. All modules come in standardised sizes and can be interconnected as desired.

Cable entries of all kinds can be mounted individually on the screwless plastic or brass flanges. Since these flanges can be inserted in a snap, cable entries can be easily mounted at any time. The same applies to other extensions or modifications.

### Bus-bar modular

A bus-bar system can be used to provide power to the individual components. The flameproof encapsulated modules (Ex-d) can be combined according to customers' specifications. Five enclosure sizes provide enough space for whatever modules are required: MCBs, RCDs, RCBOs, contactors, motor starters, over cur-

rent trips, star-delta time relays or main switches. The modules are inserted in the distribution by simple snap-on rail mounting. Thus, modules can be replaced or added quickly and reliably. Lockable actuating flaps allow operation without opening the enclosure.



### Features

- Modular slip-on assembly
- High IP66 protection
- Snap-on components
- Retrofitting



Technical data

MCB distribution for lighting circuits | heating circuits | socket distribution

Marking accd. to 2014/34/EU	⊕ II 2 G Ex eb * IIB / IIC T** Gb ⊕ II 2 D Ex tb IIIC T** °C Db
EC-Type Examination Certificate	BVS 22 ATEX E 006
Permissible ambient temperature	-20 °C up to +40 °C -55 °C up to +55 °C (option)
IECEX Certificate of Conformity	IECEX BVS 22.0008
Marking accd. to IECEx	Ex eb * IIB / IIC T** Gb Ex tb IIIC T** °C Db
(*) Optional the marking can be amplified with the types of protection of separately certified components for example „d“/„dB“/„m“/„mb“/„op is“/ und/oder „ia“/„op pr“	
(**) The values of the temperature class and the surface temperature is depending on the defined ambient temperature range and the specific power loss of each variant of distribution board.	
Rated voltage	up to 690 V (depends on components)
Rated current	up to 400 A (depends on components)
Protection class	I (II as an option)
Terminal cross section	up to 300 mm <sup>2</sup>
Degree of protection accd. to EN 60529	IP66
Weight	see ordering details
Enclosure material	glass-fibre reinforced polyester
Enclosure colour	black

Ordering details distribution for lighting circuits

Content	Type	MCB 2-pole	Connection terminals	Cable glands	Weight approx.	Order No.
40 A	1	8 x 16 A	10 mm <sup>2</sup>	1 x M40 cable gland 8 x M25 cable gland	20 kg	EXKO 214 600 G 0000
80 A	2	12 x 16 A	16 mm <sup>2</sup>	1 x M50 cable gland 12 x M25 cable gland	32 kg	EXKO 214 600 G 0001
80 A	3	24 x 16 A	16 mm <sup>2</sup>	1 x M50 cable gland 24 x M25 cable gland	56 kg	EXKO 214 600 G 0002

Ordering details distribution for heating circuits

Content	Type	RCBO 2-pole	Connection terminals	Cable glands	Weight approx.	Order No.
40 A	1	8 x 16 A, 30 mA	10 mm <sup>2</sup>	1 x M40 cable gland 8 x M25 cable gland	20 kg	EXKO 214 600 G 0003
80 A	2	12 x 16 A, 30 mA	16 mm <sup>2</sup>	1 x M50 cable gland 12 x M25 cable gland	32 kg	EXKO 214 600 G 0004
80 A	3	24 x 16 A, 30 mA	16 mm <sup>2</sup>	1 x M50 cable gland 24 x M25 cable gland	56 kg	EXKO 214 600 G 0005

Ordering details distribution for sockets

Content MCB	Type	Socket outlets	Cable glands	Weight approx.	Order No.
2 x 16 A	1	2 x 16 A 3-pole	1 x M40 cable gland	10 kg	EXKO 233 800 C 0001
2 x 16 A 1 x 32 A	2	1 x 16 A 3-pole 1 x 16 A 5-pole 1 x 32 A 5-pole	1 x M40	20 kg	EXKO 233 800 C 0002
4 x 16 A	3	2 x 16 A 3-pole 2 x 16 A 5-pole	1 x M40	25 kg	EXKO 233 800 C 0003

**MCB distribution for lighting circuits, heating circuits, socket distributions**



**Wiring diagram lighting distribution | heating circuits | socket distribution**

6

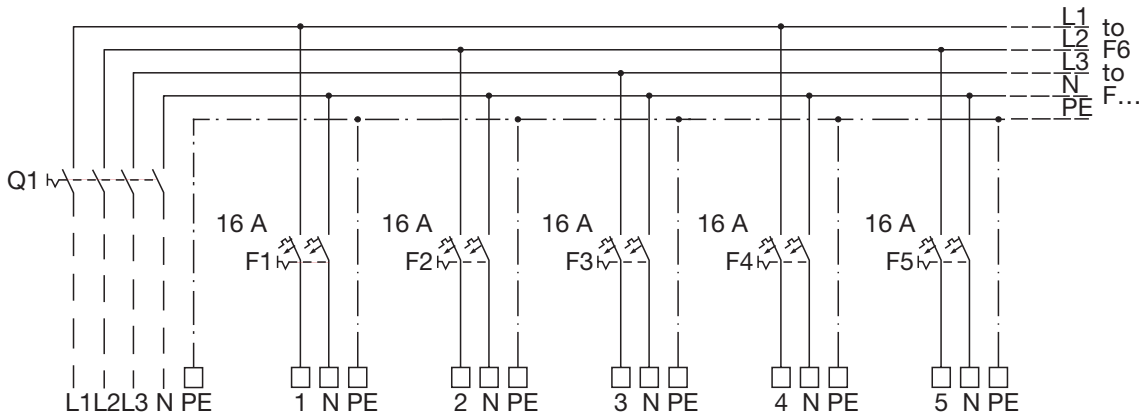

Lighting distribution

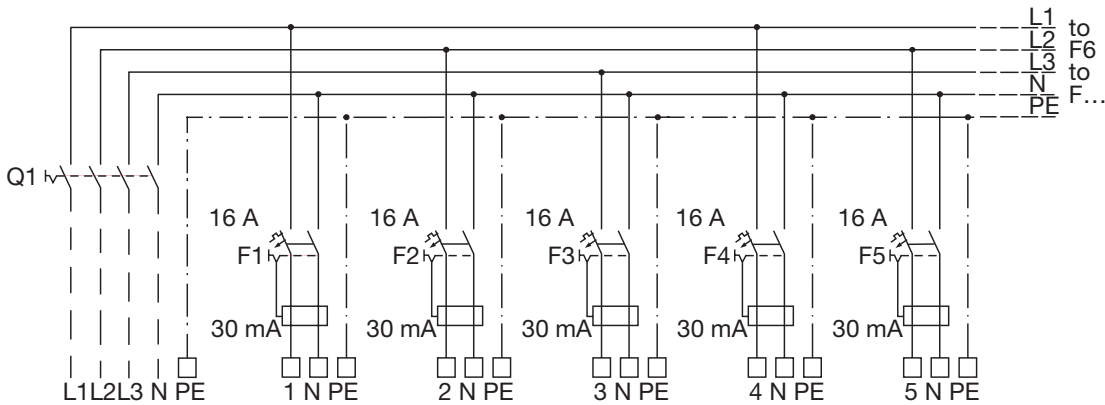

Heating circuits

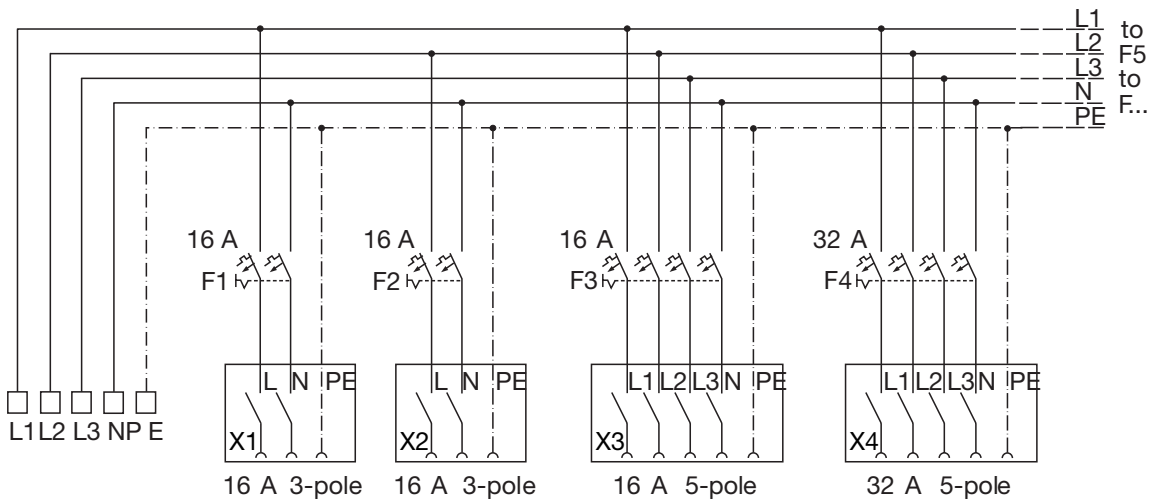

Socket distribution, must be protected by RCD



Dimension drawing lighting distribution | heating circuits | socket distribution

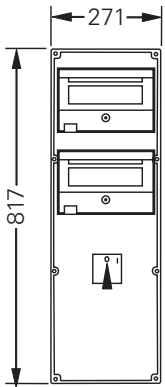

Type 1

Lighting distribution/heating circuits

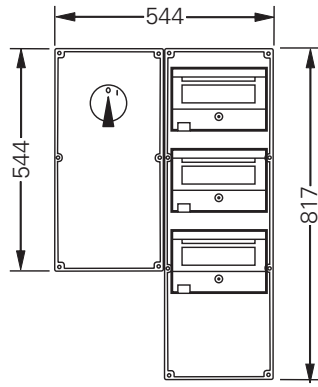

Type 2

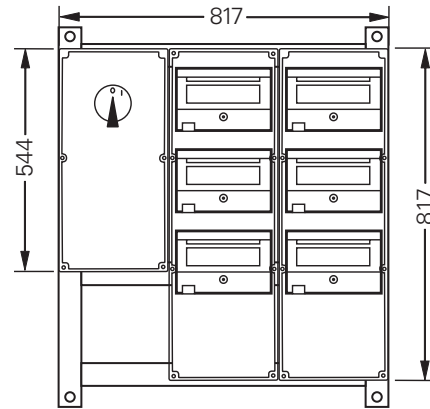

Type 3

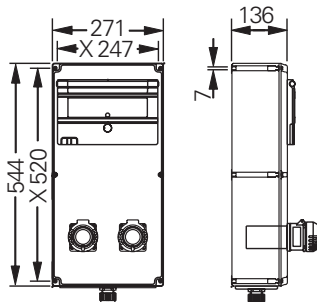

Type 1

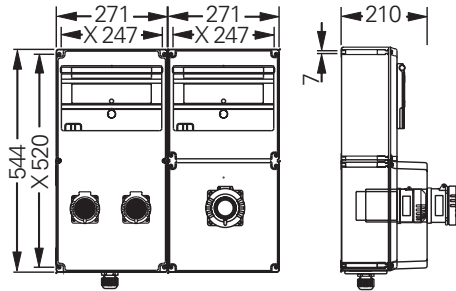

Type 2

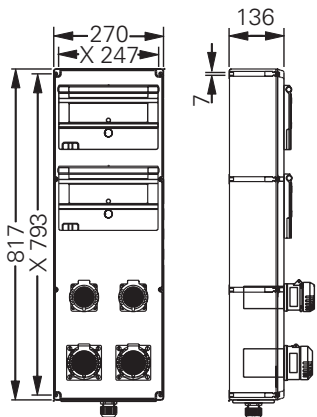

Type 3

Socket distribution

X = fixing dimension

## Twilight switch with Ex-e enclosure



EXKO 231 402 L...

### Technical data

#### Twilight switch with Ex-e enclosure

Marking accd. to 2014/34/EU	Ⓔ II 2 G Ex Ex db eb IIC T5 Gb
EC-Type Examination Certificate terminal box	GHG 721: BVS 13 ATEX E 013 X GHG 74: BVS 12 ATEX E 118 X
EC-Type Examination Certificate twilight switch	PTB 06 ATEX 1017 X
Permissible ambient temperature	-40°C to +55°C
IECEX Certificate of Conformity terminal box	GHG 721: IECEX BVS 13.0031X GHG 74: IECEX BVS 12.0071X
Marking accd. to IECEx	Ex db eb IIC T5 Gb
Rated voltage	105 - 305 V 50/60 Hz
Rated current	max. 10 A
Protection class	I
Rated switching capacity	1800 VA
Light sensitivity	4 - 11 lux, 7 - 12 lux, 10 - 15 lux, adjustable, lower value "ON", upper value "OFF"
Degree of protection accd. to EN 60529	IP66
Enclosure material	glass-fibre reinforced polyester (GHG 721 00) or stainless steel (GHG 744 21)
Enclosure colour	black or polished

### Ordering details twilight switch with Ex-e enclosure

Type of enclosure	Enclosure Material	Cable entry	Type of gland	Terminals	Order No.
GHG 721 00	GRP	direct	2 x M20 threaded plug	6 x UT2.5 + 4 x UT2.5 PE	<b>EXKO 231 402 L1121</b>
GHG 721 00	GRP	direct	2 x M20 threaded plug	3 x UT4 + 2 x UT4 PE	<b>EXKO 231 402 L1122</b>
GHG 721 00	GRP	direct	1 x M25 cable gland	3 x UT4 + 2 x UT4 PE	<b>EXKO 231 402 L1131</b>
GHG 721 00	GRP	internal earth plate	1 x M20 threaded plug	3 x UT4 + 2 x UT4 PE	<b>EXKO 231 402 L1212</b>
GHG 721 00	GRP	internal earth plate +PE	1 x M20 threaded plug	4 x WDU2,5 + 2 x WPE4 + 1 x WPE10	<b>EXKO 231 400 L3212</b>
GHG 744 21	Stainless steel	flange	1 x M20 threaded plug + 1 x M20 breathing-/ draining plug	3 x UT4 + 2 x UT4 PE	<b>EXKO 231 405 L1322</b>

Other versions available on request



EXKO 231 402 L 1122

Dimension drawing I wiring diagram

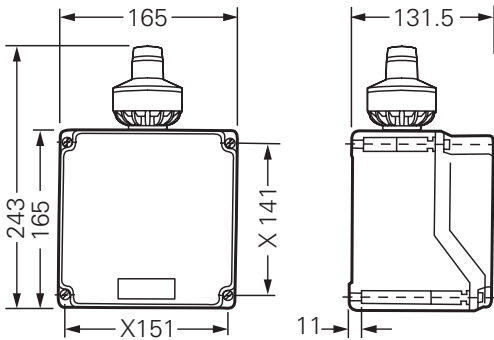

GHG 721 00

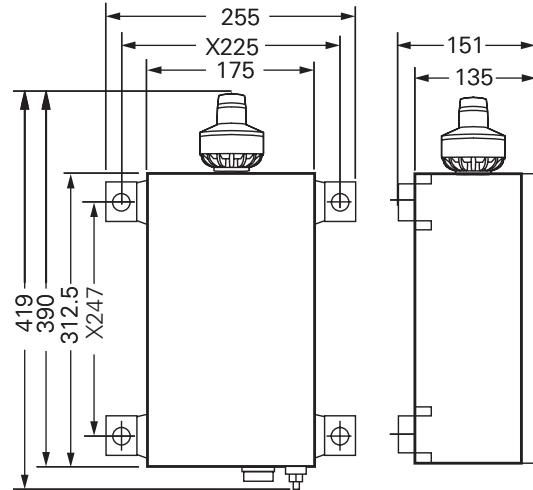

GHG 744 21

Connection diagram for 220/127 V network

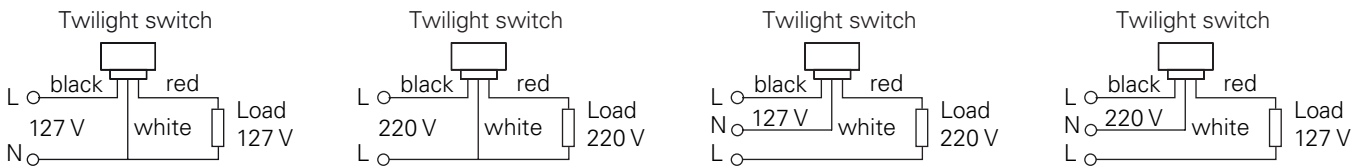

Connection diagram for 400/230 V network

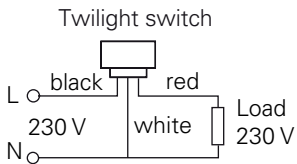

## Complete motor starter distribution

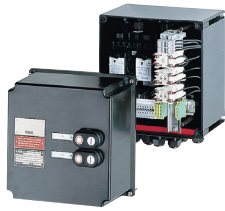

EXKO 208900 A 0001



EXKO 208900 C 0004

### Technical data

#### Complete motor starter distribution

Marking accd. to 2014/34/EU	⊕ II 2 G Ex eb * IIB / IIC T** Gb ⊕ II 2 D Ex tb IIIC T** °C Db
EC-Type Examination Certificate	BVS 22 ATEX E 006
Permissible ambient temperature	-20 °C up to +40 °C -55 °C up to +55 °C (option)
IECEX Certificate of Conformity	IECEX BVS 22.0008
Marking accd. to IECEx	Ex eb * IIB / IIC T** Gb Ex tb IIIC T** °C Db
(*) Optional the marking can be amplified with the types of protection of separately certified components for example „d“/„dB“/„m“/„mb“/„op is“/ und/oder „ia“/„op pr“	
(**) The values of the temperature class and the surface temperature is depending on the defined ambient temperature range and the specific power loss of each variant of distribution board.	
Rated voltage	690 V
Rated power	up to 22 KW
Protection class	I
Terminal cross section	up to 240 mm <sup>2</sup>
Degree of protection accd. to EN 60529	IP66
Weight	see ordering details
Enclosure material	glass-fibre reinforced polyester
Enclosure colour	black

### Ordering details complete motor starter distribution

Content Motor capacity to AC 3	Type	Connection terminals	Cable glands	Weight approx.	Order No.
<b>Direct circuit</b>					
4 KW	1	10 mm <sup>2</sup>	3 x M25 cable gland	6 kg	EXKO 208 900 A 0001
5.5 KW	2	16 mm <sup>2</sup>	3 x M25 cable gland	8 kg	EXKO 208 900 A 0002
7.5 KW	2	16 mm <sup>2</sup>	3 x M25 cable gland	8 kg	EXKO 208 900 A 0003
<b>Reversing circuit</b>					
4 KW	2	10 mm <sup>2</sup>	3 x M25 cable gland	10 kg	EXKO 208 900 B 0001
5.5 KW	2	16 mm <sup>2</sup>	3 x M25 cable gland	10 kg	EXKO 208 900 B 0002
7.5 KW	2	16 mm <sup>2</sup>	3 x M25 cable gland	10 kg	EXKO 208 900 B 0003
<b>Star-delta starter</b>					
4 KW	2	10 mm <sup>2</sup>	4 x M25 cable gland	12 kg	EXKO 208 900 C 0001
5.5 KW	2	16 mm <sup>2</sup>	4 x M25 cable gland	12 kg	EXKO 208 900 C 0002
7.5 KW	2	16 mm <sup>2</sup>	4 x M25 cable gland	12 kg	EXKO 208 900 C 0003
11 KW	3	16 mm <sup>2</sup>	1 x M25 cable gland 3 x M25 cable gland	18 kg	EXKO 208 900 C 0004
15 KW	3	16 mm <sup>2</sup>	2 x M32 cable gland 1 x M40 cable gland	18 kg	EXKO 208 900 C 0005

The motor starters are completely wired for connection by customer.

Starters for different motor power available on request. For more than 22 kW please see Ex-d light alloy motor starters on page 2.6.92, 2.6.107 or 2.6.116



EXKO 208900 C 0004



EXKO 208900 A 0001

Dimension drawing I wiring diagram

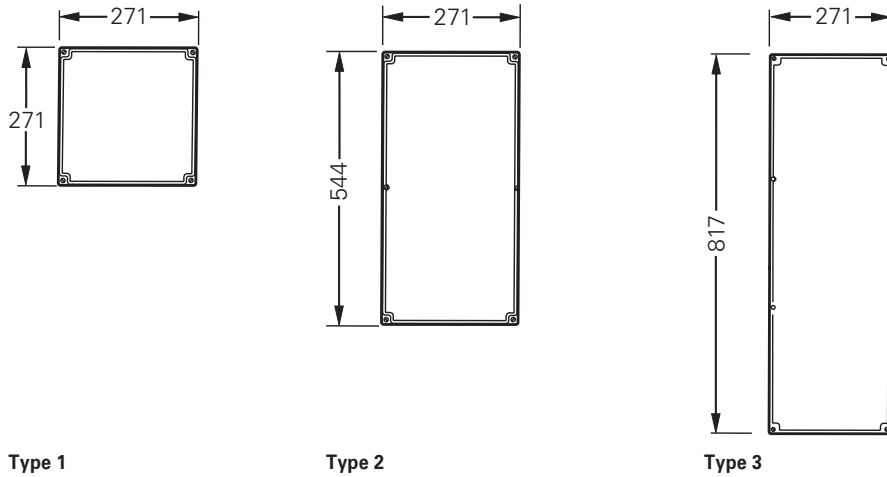

6

Direct circuit

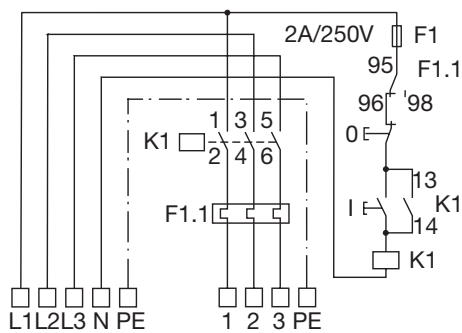

Reversing circuit

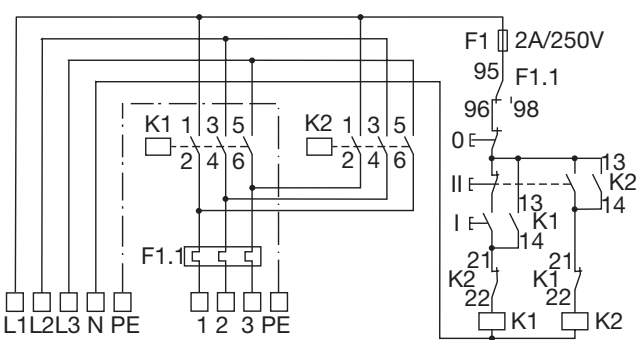

Star-delta starter

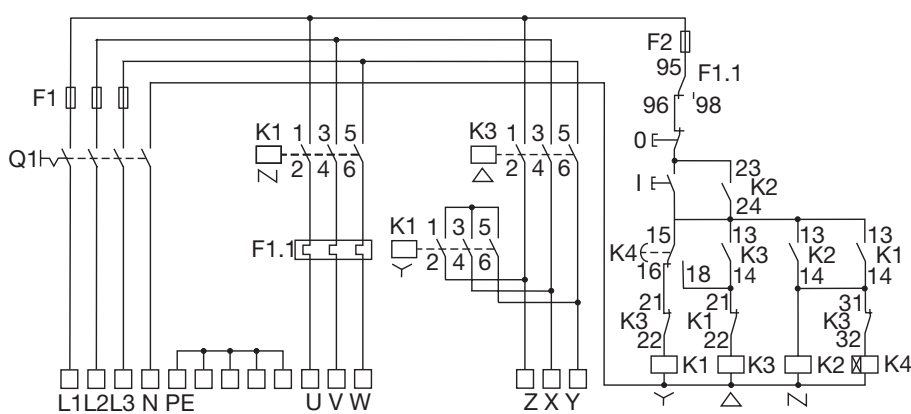



**Cooper Crouse-Hinds GmbH**

Neuer Weg-Nord 49  
69412 Eberbach  
E-Mail: [Info-Ex@Eaton.com](mailto:Info-Ex@Eaton.com)  
[www.crouse-hinds.de](http://www.crouse-hinds.de)

© 2023 Eaton  
All Rights Reserved  
Printed in Germany

Publication / 2023\_51 / MS