

Customer specific

The distributions and built-in components are combined to customers' specifications for wall-mounting or free-standing frameworks, depending on the installation site.

Free-standing frameworks are designed according to the distributions or special apparatus required and fitted with standardised U-rails. For outdoor installations, we recommend a canopy to protect the distribution from the sun and rain.

The frameworks all feature a grey epoxy resin finish identical with that of the EJ enclosures. Hot-dip galvanised steel frameworks are available on request.

The modular design makes it possible to put together distributions and built-in components using standardised enclosure sizes.

The enclosures are interconnected with cable bushings and/or bus bars and are especially designed to facilitate bus-bar allocation when putting distributions together.

Electrical components built into the enclosures can be actuated from the outside via control units mounted on the front panels. Ex-d cable entries must be used where required.

EJB enclosures are made of copper-free aluminium (<0.1%) and EJW enclosures of welded steel. All enclosures are coated with a grey epoxy resin.

Covers and enclosures are mounted on a flameproof flange plate and screwed down with stainless steel screws.

Enclosures of the types EJB 12R to EJB 23R are fitted with hinges for easy opening and closing.

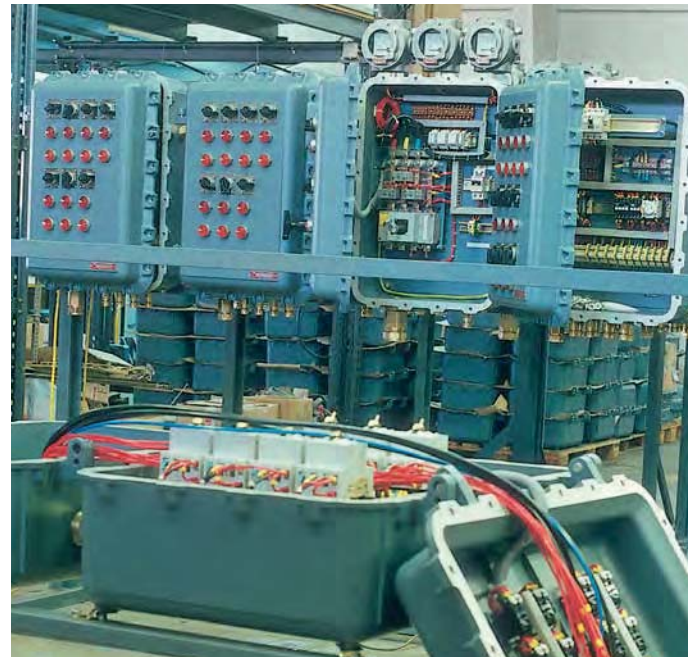

6



EJB/EJW Ex-d empty enclosures



EJB 12A



EJB 14R



EJB 23R



EJB 110

Technical data

Ex EJB/EJW enclosures light alloy/sheet steel

Marking accd. to 2014/34/EU	⊕ II 2 G Ex d IIB
EC-Type Examination Certificate	LOM 02 ATEX 3060 U
Application temperature ¹⁾	-20 °C up to +40 °C
Rated voltage	690 V
Rated current	1200 A
Protection class	I
Degree of protection accd. to EN 60529	IP65
Weight	see ordering details
Enclosure material	EJB in aluminium EJB 241 M1 and M2 cast iron EJW welded steel Front panels cast iron
Enclosure colour	epoxy-resin finish, grey

¹⁾ Depend on installation



EJB 120



EJB 130



EJB 241 M1

Ordering details

Content	Power dissipation in Watt			Rated current in A	Weight kg	Rail fixing dimension mm		Enclosure size mm			Intern. space mm			Order No.
	T6	T5	T4			D	E	H	B	T	H1	B1	T1	
EJB 12 R	30	60	100	40	3.0	242	166	215	131	102	178	89	57	NOR 000 001 170 438
EJB 12 A	30	60	100	40	3.6	242	166	215	131	162	178	89	110	NOR 000 001 170 446
EJB 14 R	80	140	240	65	8.3	436	178	412	150	143	358	103	85	NOR 000 001 170 462
EJB 23 R	60	140	240	100	11.0	354	240	336	217	212	276	163	152	NOR 000 001 170 488
EJB 110	125	170	295	160	22.0	310	310	373	373	230	305	305	162	NOR 000 001 170 496
EJB 120	150	270	480	300	28.5	414	310	474	373	230	405	305	162	NOR 000 001 170 503
EJB 120 M3	150	270	480	300	28.5	414	310	474	373	230	405	305	162	NOR 000 111 170 601
EJB 120 M4	150	270	480	300	28.5	414	310	474	373	230	405	305	162	NOR 000 111 170 606
EJB 121	150	280	500	350	32.0	414	310	474	373	295	405	305	235	NOR 000 001 170 511
EJB 130	200	340	590	450	35.3	520	310	577	373	230	518	305	162	NOR 000 001 170 529
EJB 131	200	350	610	500	39.0	520	310	577	373	295	518	305	235	NOR 000 001 170 537
EJB 240	250	400	700	800	52.3	624	414	680	474	230	619	405	162	NOR 000 001 170 545
EJB 241	250	400	700	850	56.8	624	414	680	474	295	619	405	235	NOR 000 001 170 553
EJB 241 M1	250	400	700	850	54.0	624	414	680	474	295	619	405	235	NOR 000 111 170 469
EJW 250	250	340	560	1200	145.0	852	387	890	425	280	810	345	199	NOR 000 001 190 139
EJW 251	380	520	850	1200	167.0	852	387	890	425	440	810	345	320	NOR 000 001 190 197
EJW 350	380	520	850	1200	168.0	852	502	890	540	322	810	460	250	NOR 000 001 190 171
EJW 351	450	600	1000	1200	175.0	852	502	890	540	446	810	460	375	NOR 000 001 190 062
EJW 561	600	730	1000	1200	380.0	1242	687	1280	765	386	1200	685	325	NOR 000 001 190 064

6

Dimension drawing

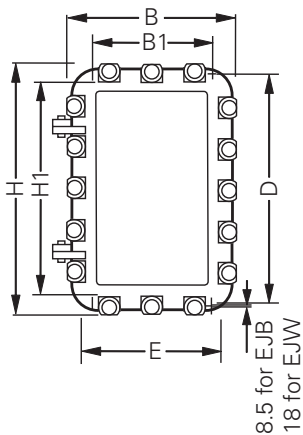

Ex-Enclosure IIB metal enclosure

EJB-Ex-d motor starter



Motor starter

Technical data

Ex EJB light-alloy motor starter

Marking accd. to 2014/34/EU	⊕ II 2 G Ex d IIB T6
EC-Type Examination Certificate	LOM 03 ATEX 2004 X
Permissible ambient temperature	-20 °C up to +40 °C
Rated voltage	690 V
Rated current	63 A
Protection class	I
Connecting terminals	up to max. 240 mm ²
Degree of protection accd. to EN 60529	IP65
Dimensions (L x H x W)	see dimension drawing
Weight	see ordering details
Enclosure material	EJB in aluminium Front panels cast iron
Enclosure colour	epoxy-resin finish, grey

Ordering details

Motor capacity	Main switch	Cable gland	Weight	Module size	Order No.
Type: Direct circuit					
4.0 kW	25 A	2 x M 25 Ex-d	4.0 kg	1	EXKO 732 101 M
4.0 kW	25 A	2 x M 25 Ex-d	12.0 kg	2	EXKO 732 102 M
5.5 kW	40 A	2 x M 25 Ex-d	12.0 kg	2	EXKO 732 103 M
8.0 kW	40 A	2 x M 25 Ex-d	16.8 kg	3	EXKO 732 104 M
12.5 kW	63 A	2 x M 32 Ex-d	17.2 kg	3	EXKO 732 105 M
15.0 kW	63 A	2 x M 32 Ex-d	18.8 kg	3	EXKO 732 106 M
Type: Star-delta starter					
12.5 kW	40 A	2 x M 25 Ex-d	17.2 kg	2	EXKO 732 113 M
18.5 kW	40 A	2 x M 32 Ex-d	19.7 kg	2	EXKO 732 114 M
25.0 kW	40 A	2 x M 32 Ex-d	25.3 kg	3	EXKO 732 115 M
Type: Reversing circuit					
4.0 kW	25 A	2 x M 25 Ex-d	4.0 kg	1	EXKO 732 107 M
4.0 kW	25 A	2 x M 25 Ex-d	12.0 kg	2	EXKO 732 108 M
5.5 kW	40 A	2 x M 25 Ex-d	12.0 kg	2	EXKO 732 109 M
8.0 kW	40 A	2 x M 25 Ex-d	16.8 kg	3	EXKO 732 110 M
12.5 kW	63 A	2 x M 32 Ex-d	17.2 kg	3	EXKO 732 111 M
15.0 kW	63 A	2 x M 32 Ex-d	18.8 kg	3	EXKO 732 112 M

Other switching capacities, soft starter and variable speed drives on request



Motor starter

Wiring diagram | Dimension drawing

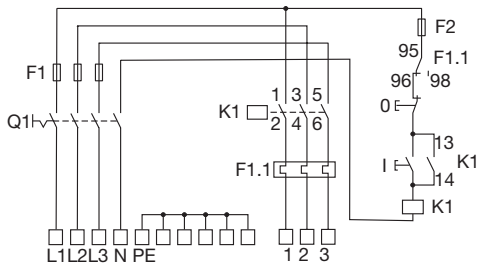

Direct on-line starter

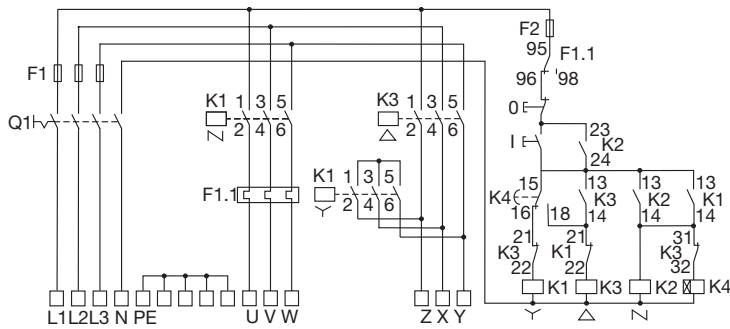

Star-delta starter

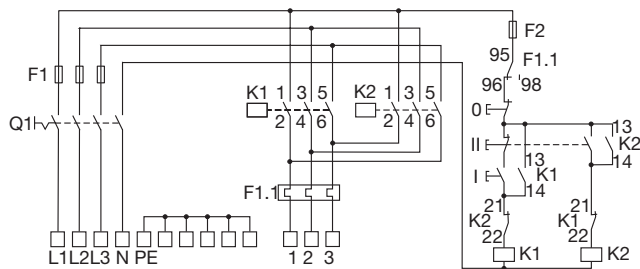

Reversing circuit

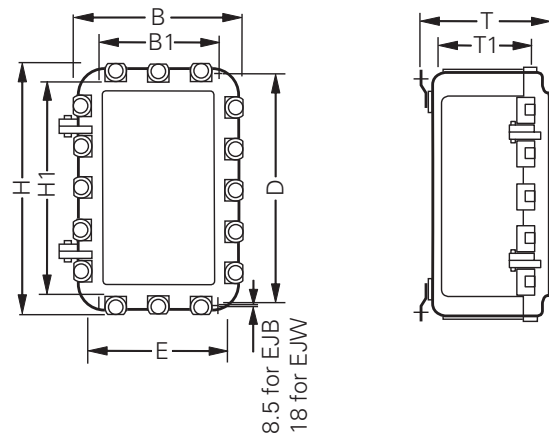

Version	Rail fixing dimensions mm		Enclosure size mm			Internal space mm		
	D	E	H	B	T	H1	B1	T1
1	242	166	215	131	102	178	89	57
2	436	178	412	150	143	358	103	85
3	354	240	336	217	212	276	163	152