

### Distributions

If electrical apparatus is to be used in hazardous areas, i.e. potentially explosive atmospheres, where arcing or sparking can occur, it must be protected according to EN 60079 pp. by special constructional measures. CEAG explosion-protected products derive their high degree of safety through the combination of various types of protection. Thus, flameproof encapsulated devices (Ex-d), for instance, are also integrated in enclosures of the „Increased Safety“ type (Ex-e). As these components are of modular design, they can be combined ac-

ording to customers' requirements. The modules are inserted by simple snap-on rail mounting. Electrical apparatus with metal enclosures may be used in type „flameproof enclosure“ (E-d) without any volume limit. Up to three high-capacity apparatus with non-metal enclosures may take up an enclosure volume of up to 2000 cm<sup>3</sup>. However, the heat generated in the enclosure must be dissipated, so that the temperature on the external surface of the enclosure does not exceed the limit set by the respective temperature class.

### Product range

The extensive CEAG product range offers everything you're looking for – just in time: no matter whether you need a flameproof encapsulated component, an encapsulation of the components in a flameproof enclosure – or a combination of both.

### Material

Whatever material you care for, CEAG has it: Distributions are available in the most diverse materials, such as glass-fibre reinforced polyester, electro-polished stainless steel or die-cast light alloy in explosion group IIB and IIC or alternatively polyester powder-coated steel. The explosion-protected CEAG distributions are certified for hazardous areas of Zones 1 and 2. We also have the right solution for Zones 21 and 22 for you.

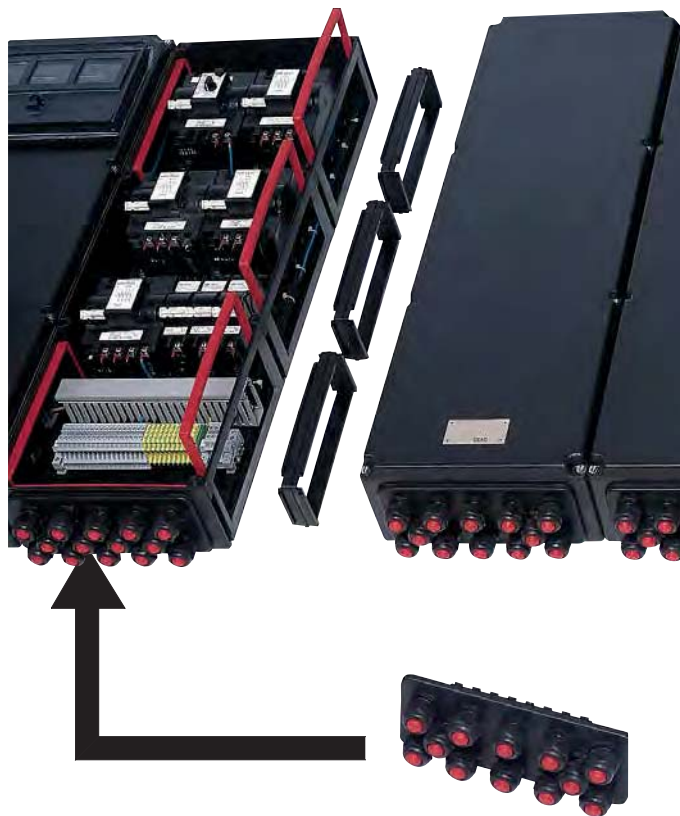

### Snapy snap-on

The Cooper Crouse-Hinds GmbH gives you explosion protection in a snap – even with distributions. The enclosures and the main switches are of modular design in standardised sizes and can thus be combined as desired using the reliable flange snap-on mounting technique. Cable entries of all kinds can be mounted individually on the screwless plastic or brass flanges. And since these flanges can be inserted in a snap, cable entries can be easily mounted at any time. The same applies to other extensions or modifications. The snap-on technique gives you greater flexibility and cost-effectiveness for installations in hazardous areas.

### Modular design

The modular distribution design makes modifications and extensions a snap: Remove the flange, insert the new enclosure, connect the apparatus, done! Moreover, you can do this as often as your system demands. The only limitation is space.

### Rational component replacement

Components which can be quickly and reliably removed and inserted with the snap-on technique provide you with a rational method of replacing components for servicing as well as a simple and easy means of system extension.



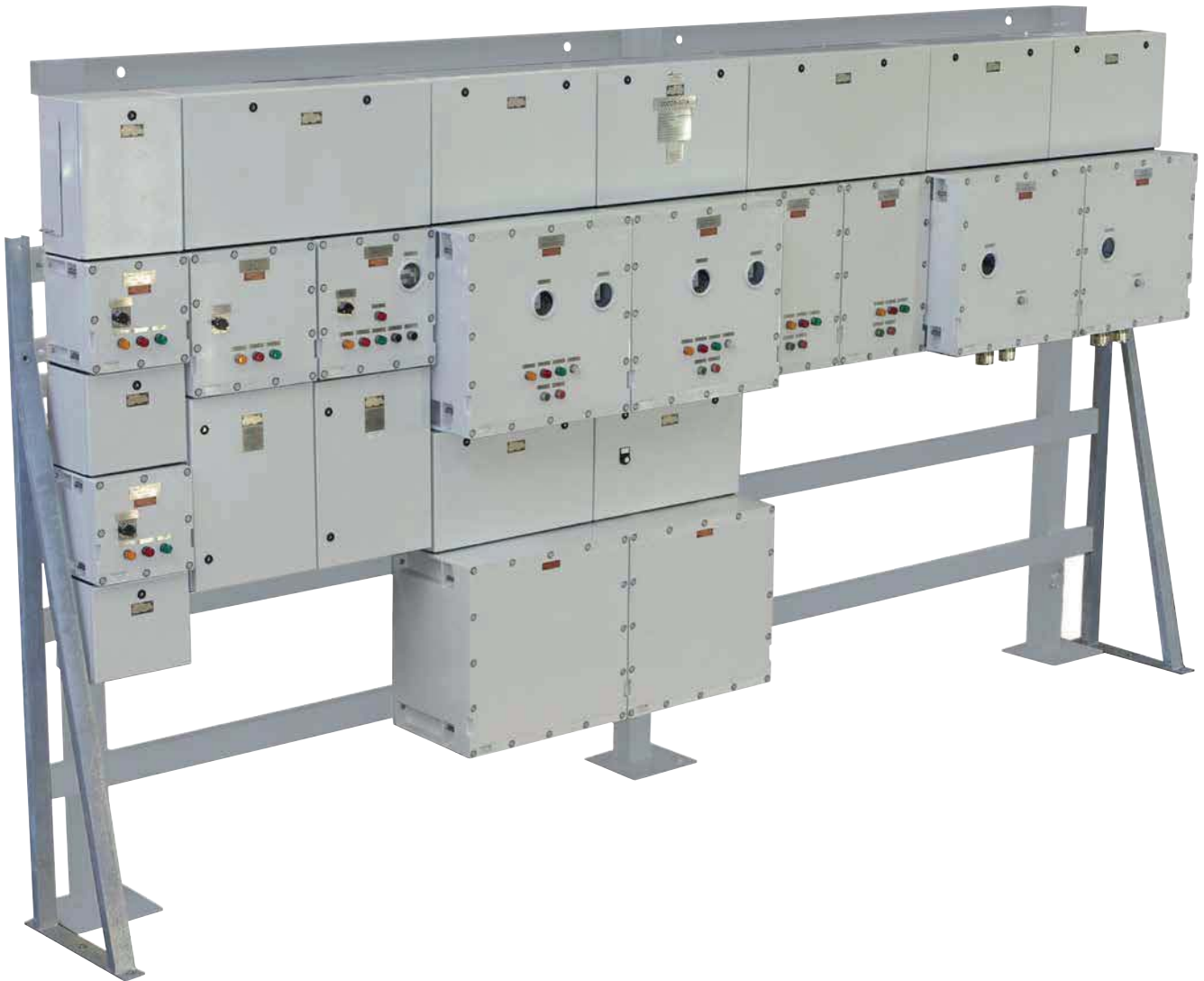

### Frameworks

Modular CEAG enclosures of different series can be combined into large distribution systems on standardised wall-mounting or free-standing frameworks. The frameworks come in standardised sizes to accommodate the enclosure modules and can be extended as required. For outdoor installations, we recommend canopies to protect the distribution system from the sun and rain. Smaller distributions are mounted on flat or U-rails. All enclosures are made of galvanised steel or – as an option – stainless steel.

### Bus bars

Inexpensive installations: Using the CEAG bus-bar system, a number of circuits can be simply and quickly connected for high cost-effectiveness. If required, individually encapsulated control and indicating units, such as pushbuttons, control switches or measuring instruments, can also be connected to the bus bars.

### Worldwide approvals

We have years of experience with explosion-protection approvals worldwide and we carefully monitor the latest trends and developments. For our customers, this means not only better consultation, but future-proof products, such as ATEX-compatible systems and components. IECEx-Scheme conform products will be taken for granted.





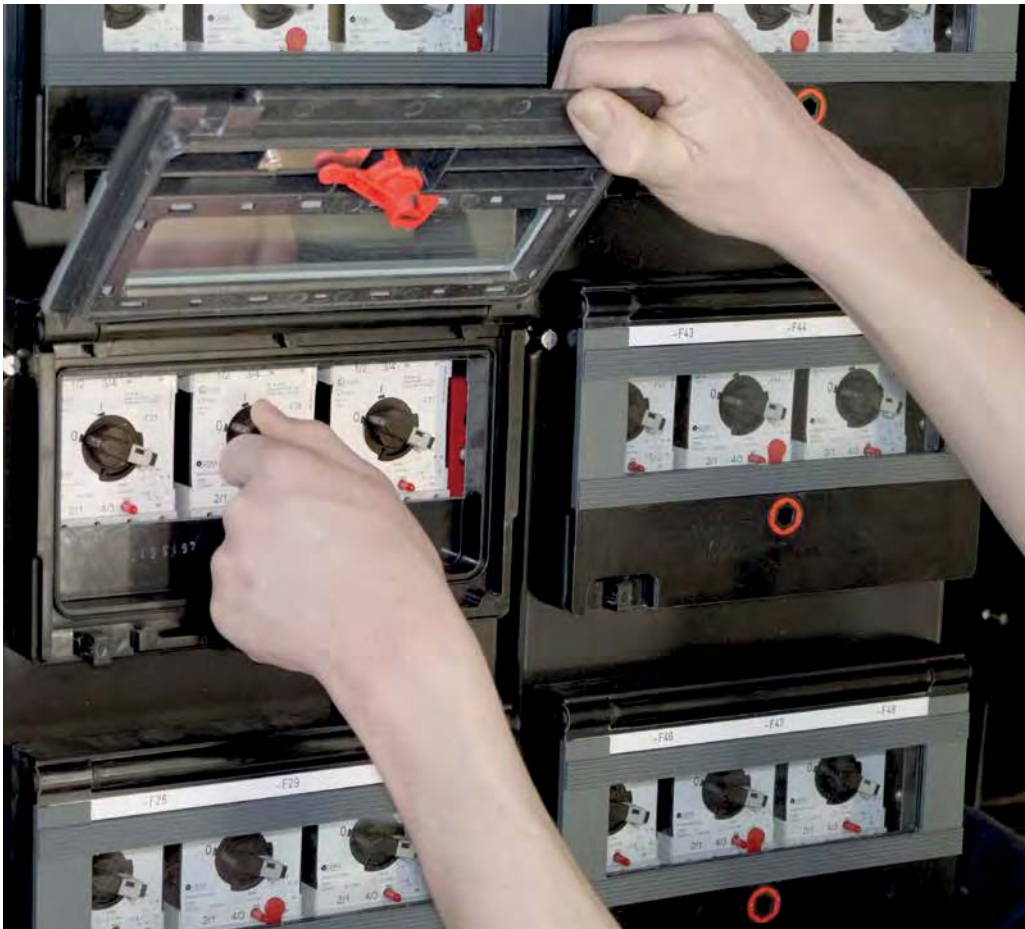

### Actuating flaps

Via actuating flaps, integrated in the enclosure cover, switches and relays can be actuated without opening the enclosure. The switch positions of the built-in components can be seen from the outside. As an added security measure, the actuating flaps can be locked.

### Explosion groups IIB (+H2) and IIC

Eaton's Crouse-Hinds Business offers a complete product line of Ex-d distributions for gas explosion groups IIB and IIC. All common industrial switchgear that gives off arcs or sparks can be built into flameproof enclosures. The distributions for explosion group IIC are designed for easy installation via „Increased Safety“ type connection boxes. Enclosures in explosion group IIB are interconnected via flameproof cable bushings.

### Planning and customized solutions

Regardless of whether you have an idea in mind or functional descriptions and wiring diagrams on paper, talk to our experienced project specialists. Our highly-qualified engineers and master technicians will provide you with expert advice and an offer. If you wish, they will also compile the needed documentation for your project (including a parts list as well as dimension, wiring and terminal diagrams as necessary) – on paper or as data files. You can rely on our flexible production for the assembly of your system. All systems and their components are 100% inspected and tested. You're welcome to perform a final acceptance test – including a complete electrical function test – in our laboratory.



# 6.1

## Ex-Distributions in Moulded Plastic Design

Modular design GHG 619

### Safety for your protection

CEAG products provides explosion protection in a snap – and that also applies to distributions.

Electrical distributions for Ex-areas must be protected according to EN 60079 by constructional measures. Thus, the Eaton's Crouse-Hinds Business flameproof moulded-plastic distributions provide type Ex-e protection.

The enclosure and main-switch modules are available in the following materials: fibreglass reinforced polyester, electro-polished stainless steel and polyester powder-coated steel. Moulded plastic enclosures are flame-retardant according to UL 94 VO. All modules come in standardised sizes and can be interconnected as desired.

Cable entries of all kinds can be mounted individually on the screwless plastic or brass flanges. Since these flanges can be inserted in a snap, cable entries can be easily mounted at any time. The same applies to other extensions or modifications.

### Bus-bar modular

A bus-bar system can be used to provide power to the individual components. The flameproof encapsulated modules (Ex-d) can be combined according to customers' specifications. Five enclosure sizes provide enough space for whatever modules are required: MCBs, RCDs, RCBOs, contactors, motor starters, over cur-

rent trips, star-delta time relays or main switches. The modules are inserted in the distribution by simple snap-on rail mounting. Thus, modules can be replaced or added quickly and reliably. Lockable actuating flaps allow operation without opening the enclosure.



### Features

- Modular slip-on assembly
- High IP66 protection
- Snap-on components
- Retrofitting



Technical data

MCB distribution for lighting circuits | heating circuits | socket distribution

Marking accd. to 2014/34/EU	Ⓢ II 2 G Ex de ia/ib m [ia/ib] IIC T6/T5/T4 Ⓢ II 2 D Ex tD A21 IP66/IP65 T80 °C, T95 °C
EC-Type Examination Certificate	PTB 99 ATEX 1044
Permissible ambient temperature	-20 °C up to +40 °C -55 °C up to +55 °C (option)
IECEX Certificate of Conformity	IECEX BKI 06.0007
Marking accd. to IECEx	Ex de ia/ib m [ia/ib] T4 ... T6 Ex tD A21 IP66 T80 °C
Rated voltage	up to 690 V (depends on components)
Rated current	up to 315 A (depends on components)
Protection class	I (II as an option)
Terminal cross section	up to 300 mm <sup>2</sup>
Degree of protection accd. to EN 60529	IP66
Weight	see ordering details
Enclosure material	glass-fibre reinforced polyester
Enclosure colour	black

6

Ordering details distribution for lighting circuits

Content	Type	MCB 2-pole	Connection terminals	Cable glands	Weight approx.	Order No.
40 A	1	8 x 16 A	10 mm <sup>2</sup>	1 x M40 cable gland 8 x M25 cable gland	20 kg	EXKO 214 600 G 0000
80 A	2	12 x 16 A	16 mm <sup>2</sup>	1 x M50 cable gland 12 x M25 cable gland	32 kg	EXKO 214 600 G 0001
80 A	3	24 x 16 A	16 mm <sup>2</sup>	1 x M50 cable gland 24 x M25 cable gland	56 kg	EXKO 214 600 G 0002

Ordering details distribution for heating circuits

Content	Type	RCBO 2-pole	Connection terminals	Cable glands	Weight approx.	Order No.
40 A	1	8 x 16 A, 30 mA	10 mm <sup>2</sup>	1 x M40 cable gland 8 x M25 cable gland	20 kg	EXKO 214 600 G 0003
80 A	2	12 x 16 A, 30 mA	16 mm <sup>2</sup>	1 x M50 cable gland 12 x M25 cable gland	32 kg	EXKO 214 600 G 0004
80 A	3	24 x 16 A, 30 mA	16 mm <sup>2</sup>	1 x M50 cable gland 24 x M25 cable gland	56 kg	EXKO 214 600 G 0005

Ordering details distribution for sockets

Content MCB	Type	Socket outlets	Cable glands	Weight approx.	Order No.
2 x 16 A	1	2 x 16 A 3-pole	1 x M40 cable gland	10 kg	EXKO 233 800 C 0001
2 x 16 A 1 x 32 A	2	1 x 16 A 3-pole 1 x 16 A 5-pole 1 x 32 A 5-pole	1 x M40	20 kg	EXKO 233 800 C 0002
4 x 16 A	3	2 x 16 A 3-pole 2 x 16 A 5-pole	1 x M40	25 kg	EXKO 233 800 C 0003

**MCB distribution for lighting circuits, heating circuits, socket distributions**



**Wiring diagram lighting distribution | heating circuits | socket distribution**

6

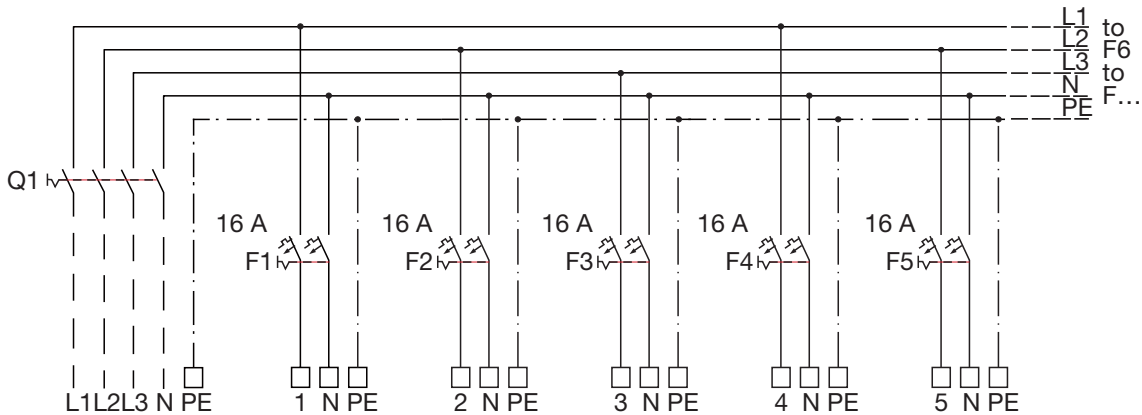

Lighting distribution

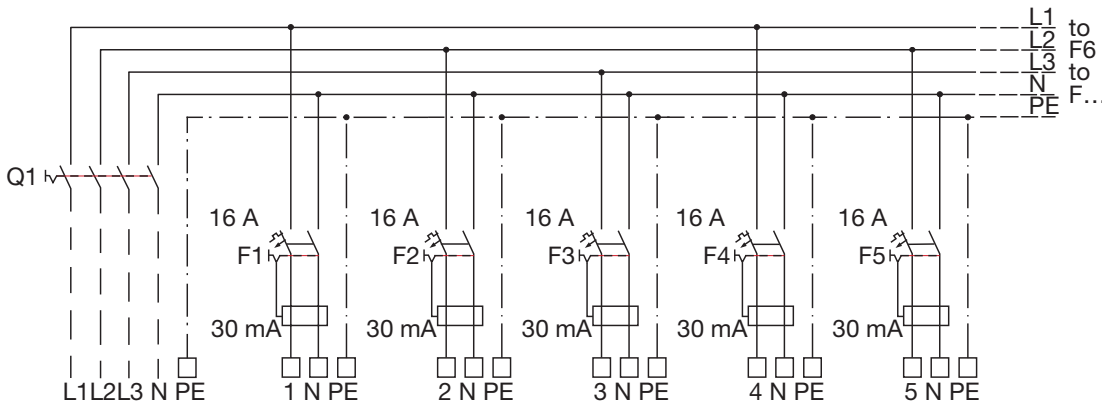

Heating circuits

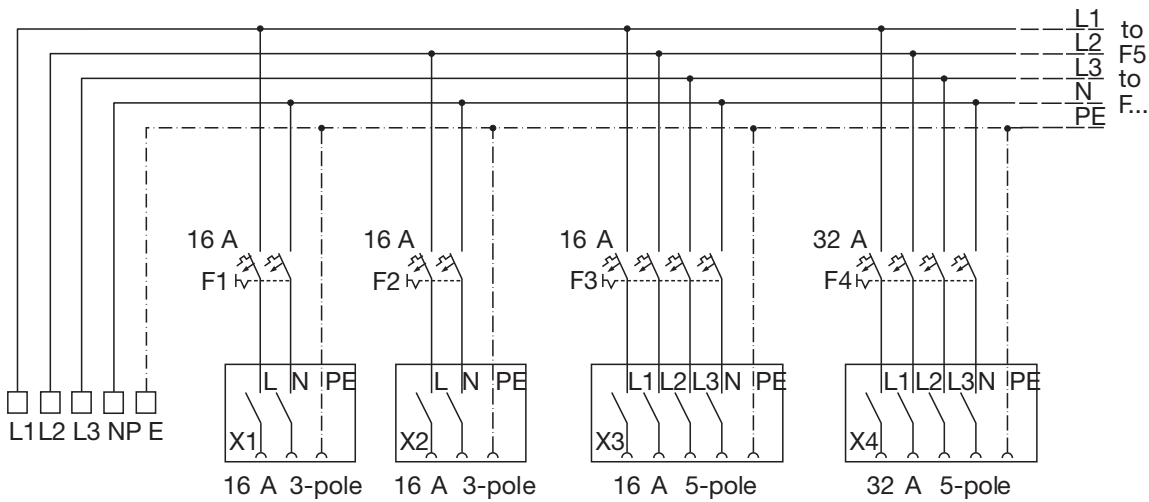

Socket distribution, must be protected by RCD



Dimension drawing lighting distribution | heating circuits | socket distribution

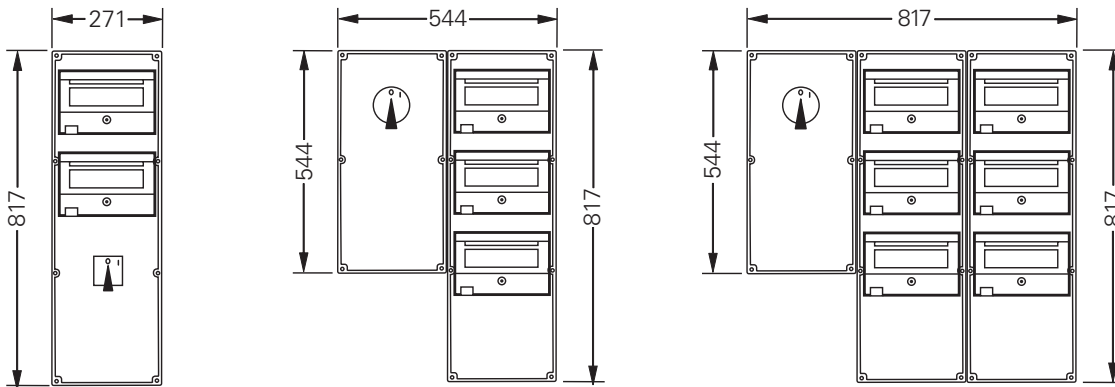

Type 1

Type 2

Type 3

Lighting distribution/heating circuits

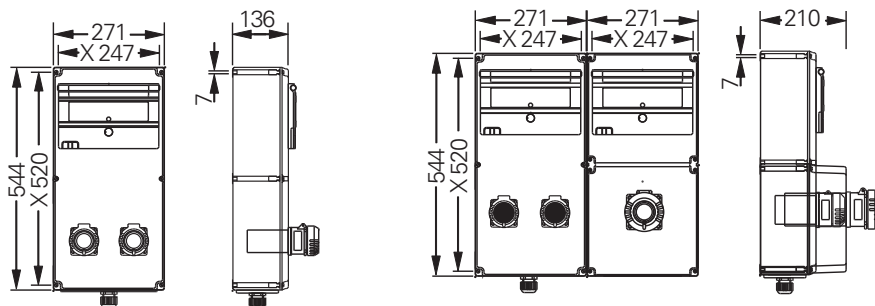

Type 1

Type 2

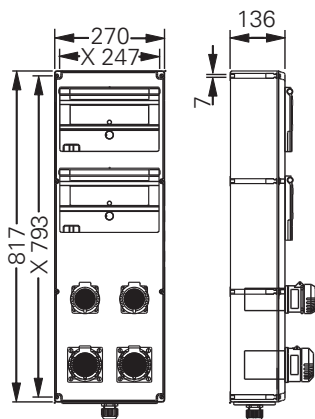

Type 3

Socket distribution

X = fixing dimension